

1 2 3 4 5 6 7 8

| REVISIONS | | |
|-----------|------|---------------------------|
| ISS | ZONE | DESCRIPTION\APPROVED\DATE |
| | | |

業務部

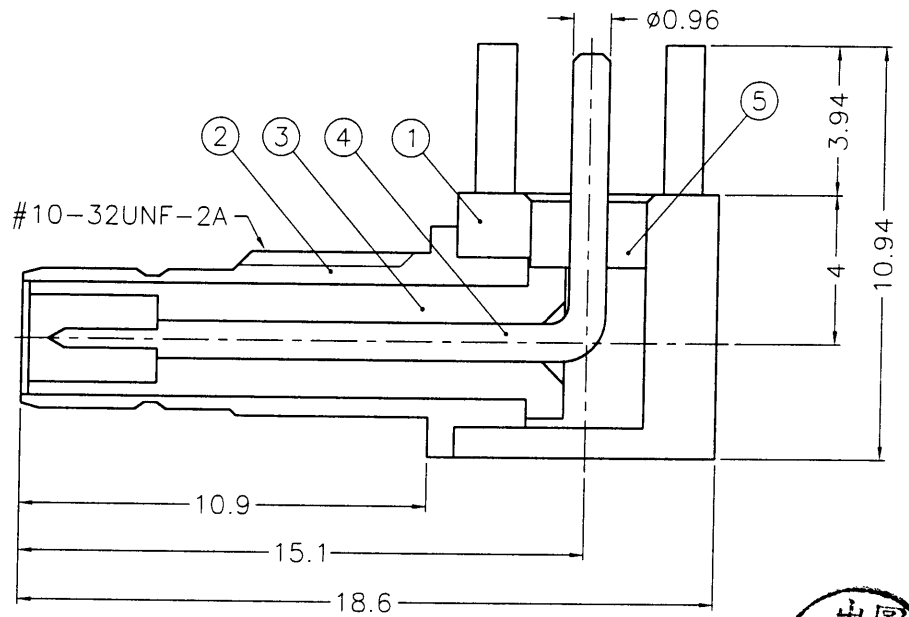
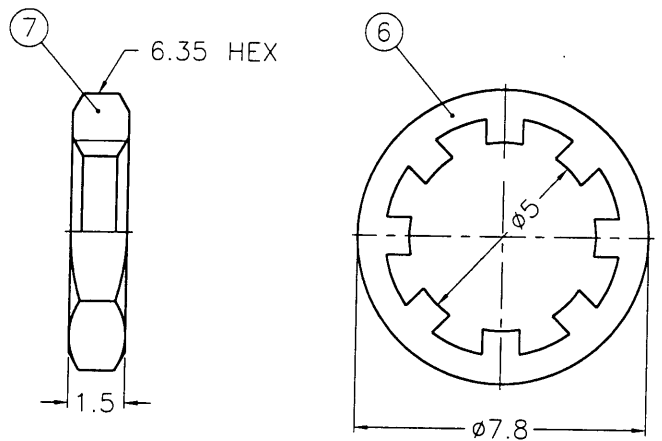
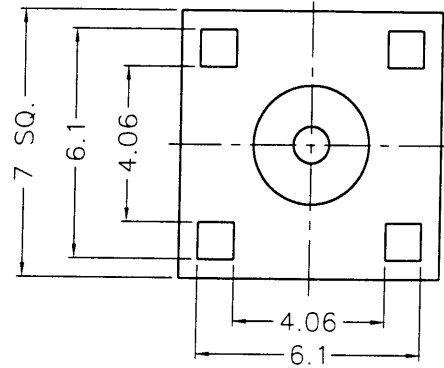

- NOTES: FINISH (PLATING THICKNESS IN MICRO-INCHES)
- BRASS PER QQ-B-626
 - BRASS PER QQ-B-613
 - GOLD PL. 3 MIN. THICK OVER NICKEL PL. 100 MIN. THICK OVER COPPER STRIKE
 - GOLD PL. 30 MIN. THICK OVER NICKEL PL. 100 MIN. THICK OVER COPPER STRIKE
 - TEFLON MIL-P-19468

出圖
87.12.11
R&D

| NO. | DESCRIPTION | MATERIAL | FINISH | Q'TY | DRAWING NO. | SCALE | S/1 | ISSUE | A |
|-----|-------------|----------|--------|---------|-------------|----------------|-----|-------|---|
| 7 | HEX NUT | | NOTE 1 | NOTE 3 | 1 | HN635-10-32X15 | | | |
| 6 | LOCK WASHER | | NOTE 2 | NOTE 3 | 1 | LW-78/5X05 | | | |
| 5 | INSULATOR | | NOTE 5 | NATURAL | 1 | SMB74971-5T-50 | | | |
| 4 | CONTACT PIN | | NOTE 1 | NOTE 4 | 1 | SMB74971-4-A | | | |
| 3 | INSULATOR | | NOTE 5 | NATURAL | 1 | SMB74971-3T-50 | | | |
| 2 | BODY | | NOTE 1 | NOTE 3 | 1 | SMB74971-2-A | | | |
| 1 | HOUSING | | NOTE 1 | NOTE 3 | 1 | SMB74971-1 | | | |

| | | | |
|---------------------------------------|--|-----------------------------------------|--|
| DIMENSIONS ARE IN MILLIMETERS | | PART NO. | |
| UNLESS OTHERWISE SPECIFIED TOLERANCES | | APPROVED <i>Mark C</i> DATE 12-09-98' | |
| 0.5-6 = ±0.2 | | CHECKED <i>Mark C</i> DATE 12-09-98' | |
| 6-30 = ±0.4 | | DRAWN <i>Betty L</i> DATE 12-09-98' | |
| 30-120 = ±0.6 | | TITLE | |
| 120-315 = ±1 | | SMB R/A P.C. MOUNT JACK | |
| 315-1000 = ±1.6 | | DRAWING NO. | |
| 1000-2000 = ±2.4 | | SMB74971-001-3GT30G-50 | |
| | | FILE NO. F:\DWG\SMB\74971\001\50\3GT30G | |



KAI JACK INDUSTRIAL CO., LTD.
TAINAN TAIWAN R.O.C.

SMB Rev 37