

REVISIONS		
ISS	ZONE	DESCRIPTION\PER REQUEST\DATE

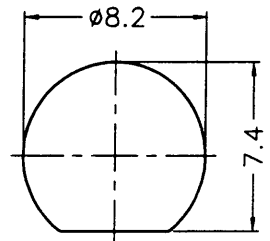

RECOMMENDED MOUNTING HOLE  
(建議架設孔)

REMARK : 1. SOLDER PIN #2 TO BODY THEN SEAL IT WITH EPOXY  
(1. 針 #2 須焊接於主體的內側不限任何方向並用環氧樹脂覆蓋)

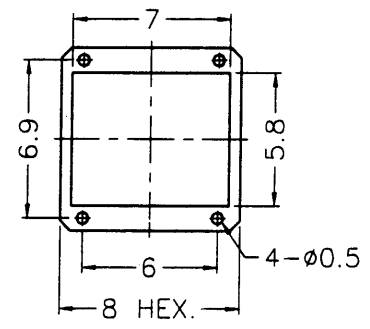
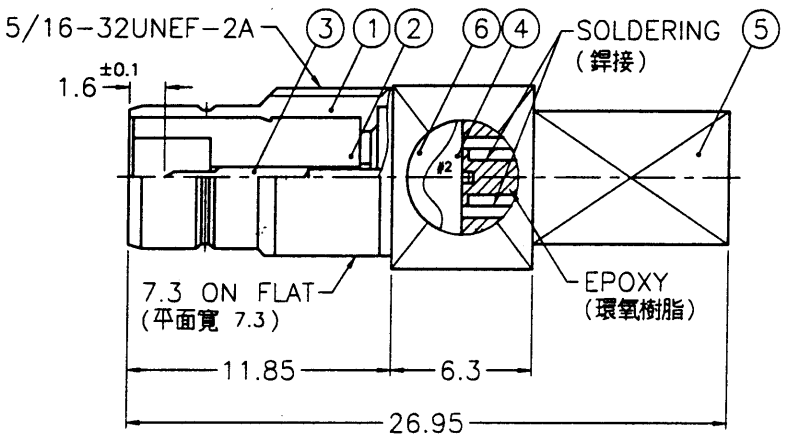
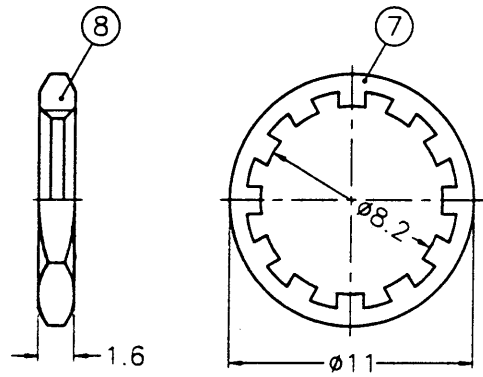

- NOTES: FINISH (PLATING THICKNESS IN MICRO-INCHES)
- BRASS PER QQ-8-626
  - BRASS PER QQ-8-613
  - GOLD PL. 3 MIN. THICK OVER NICKEL PL. 100 MIN. THICK OVER COPPER STRIKE
  - GOLD PL. 30 MIN. THICK OVER NICKEL PL. 100 MIN. THICK OVER COPPER STRIKE
  - TEFLON MIL-P-19468
  - PURCHASED FROM CUSTOMER (向客戶購買)



1. MAX. PANEL THICKNESS=3.3mm

NO.	DESCRIPTION	MATERIAL	FINISH	Q'TY	DRAWING NO.
8	HEX NUT			1	HN95-5/16-32 X16
7	LOCK WASHER			1	LW-11/82X05
6	COVER			1	CV-5X05-T
5	MOLEX			1	52007-0210
4	TRANSFORMER			1	TF00AAA01A
3	CONTACT PIN			1	CP43AAM02A
2	INSULATOR		NATURAL	1	NS26AAM02A
1	BODY			1	BD26AAZ01A

DIMENSIONS ARE IN MILLIMETERS				PART NO.	
UNLESS OTHERWISE SPECIFIED TOLERANCES				APPROVED	DATE
0.5-6	= ±0.2			<i>gackey</i>	10-24-02'
6-30	= ±0.4				
30-120	= ±0.6			CHECKED	DATE
120-315	= ±1			<i>Ken</i>	10-24-02'
315-1000	= ±1.6			DRAWN	DATE
1000-2000	= ±2.4			<i>Ken</i>	10-24-02'
SCALE	3/1	ISSUE	A	FILE NO. F:\DWG\SMZ\140100\75\3GT30G	

<b>Amphenol</b>	
Danbury,CT,USA-Tainan,Taiwan-Shenzhen,China	
TITLE	SMZ 75/120 ohm BALUN PLUG
DRAWING NO.	KJ-SMZ140100-3GT30G-75
ITEM NO.	261401AAA1GE7F

7RD-DR R8-5 8