

REVISIONS		
ISS	ZONE	DESCRIPTION\PER REQUEST\DATE

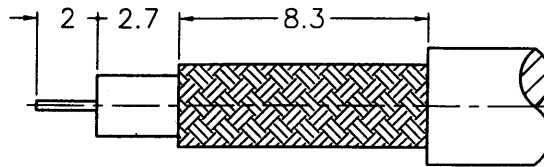

RECOMMENDED
CABLE STRIPPING DIM'S
(建議剝線尺寸)

SALES

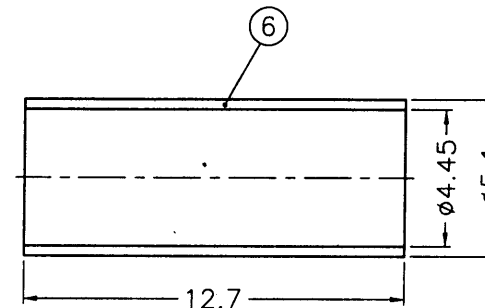
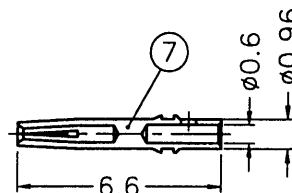
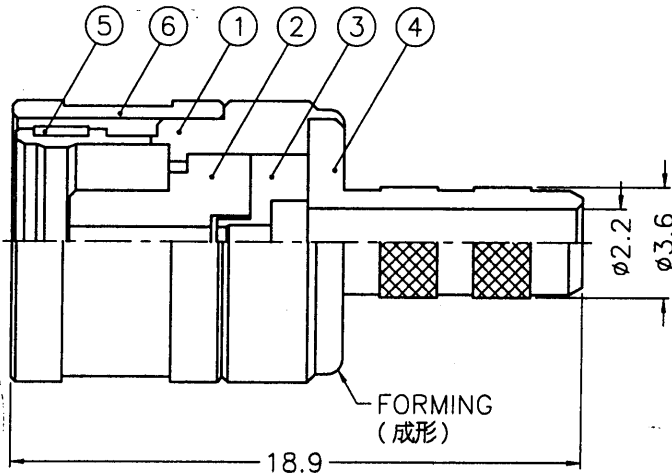

NOTES: FINISH (PLATING THICKNESS IN MICRO-INCHES)

- 1. BRASS PER QQ-B-626
- 2. GOLD PL. 3 MIN. THICK OVER NICKEL PL. 100 MIN. THICK OVER COPPER STRIKE
- 3. BERYLLIUM COPPER PER QQ-C-530
- 4. GOLD PL. 30 MIN. THICK OVER NICKEL PL. 100 MIN. THICK OVER COPPER STRIKE
- 5. TEFLON MIL-P-19468
- 6. JIS H 3250, C 2600

ISSUED
2003. 2. 25
R.D.

- 1. CRIMPED FERRULE
HEX. CRIMP SIZE .178"
- 2. CONTACT PIN TO SOLDER

8	FERRULE	NOTE 6	NOTE 2	1	FR-51/445X127
7	CONTACT PIN	NOTE 3	NOTE 4	1	SMB6121B2-5-096/06-D
6	SHELL	NOTE 1	NOTE 2	1	SMB5003-1-75
5	RETAINER RING	NOTE 3	NATURAL	1	SMB5003-8-75
4	BARREL	NOTE 1	NOTE 2	1	BR00ABU07A
3	INSULATOR	NOTE 5	NATURAL	1	SMB6121A6-3T-8218
2	INSULATOR	NOTE 5	NATURAL	1	SMB6121A6-2T-75
1	BODY	NOTE 1	NOTE 2	1	SMB6121A6-1-B
NO.	DESCRIPTION	MATERIAL	FINISH	Q'TY	DRAWING NO.

DIMENSIONS ARE IN MILLIMETERS
UNLESS OTHERWISE SPECIFIED TOLERANCES
0.5-6 = ±0.2
6-30 = ±0.4
30-120 = ±0.6
120-315 = ±1
315-1000 = ±1.6
1000-2000 = ±2.4

PART NO.	
APPROVED	DATE
<i>Gaucky</i>	02-24-03'
CHECKED	DATE
<i>Gaucky</i>	02-24-03'
DRAWN	DATE
<i>Gaucky</i>	02-24-03'
FILE .NO.	FILE
FDWGS\SMZ\6111A5\3002-75\3GT30G	

Amphenol	
Danbury,CT,USA-Tainan,Taiwan-Shenzhen,China	
TITLE	SMZ CRIMP PLUG
DRAWING NO.	SMZ6111A5-3GT30G-3002-75
ITEM NO.	266111AAA32GE7F

F
E
D
C
B
A

F
E
D
C
B
A

780-DR/1755-8