

1	REVISIONS
2	DESCRIPTION \ PER REQUEST \ DATE
3	
4	
5	
6	
7	
8	

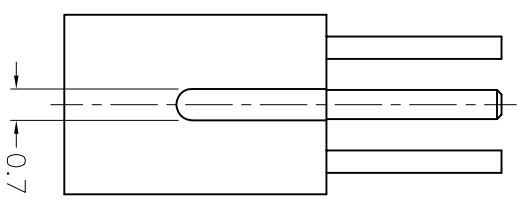
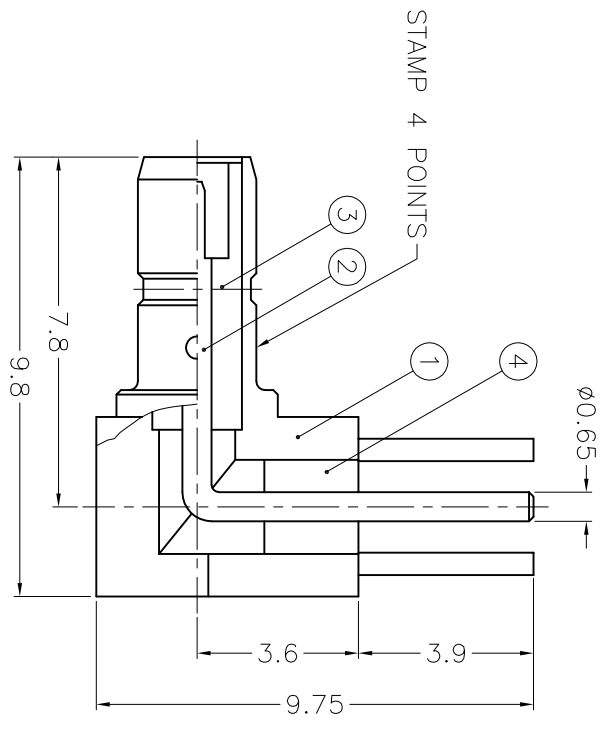
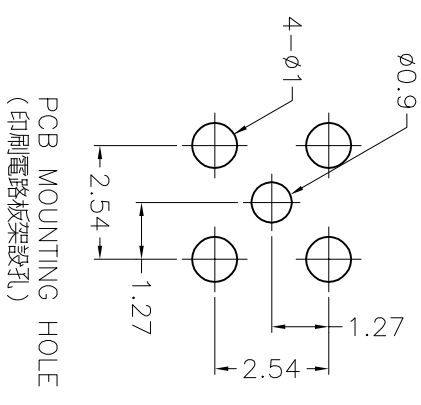
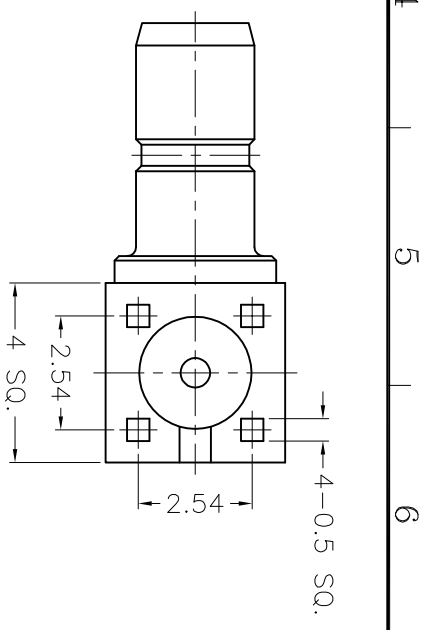

- NOTES: FINISH (PLATING THICKNESS IN MICRO-INCHES)
1. BRASS PER 00-B-626
 2. GOLD PL. 3 MIN. THICK OVER NICKEL PL. 100 MIN. THICK OVER COPPER STRIKE
 3. GOLD PL. 50 MIN. THICK OVER NICKEL PL. 100 MIN. THICK OVER COPPER STRIKE
 4. TEFLON MIL-P-19468

4	INSULATOR	NOTE 4	NATURAL	1	NS00AGM30A
3	INSULATOR	NOTE 4	NATURAL	1	NS15AAH01A
2	CONTACT PIN	NOTE 1	NOTE 3	1	CP15AAF01A
1	BODY	NOTE 1	NOTE 2	1	
NO.	DESCRIPTION	MATERIAL	FINISH	Q'TY	DRAWING NO.

DIMENSIONS ARE IN MILLIMETERS		PART NO.
UNLESS OTHERWISE SPECIFIED TOLERANCES		APPROVED
0.5-6 = ±0.2		DATE
6-30 = ±0.4		10-01-03'
30-120 = ±0.6		CHECKED
120-315 = ±1		DATE
315-1000 = ±1.6		10-01-03'
1000-2000 = ±2.4		DRAWN
		DATE
		10-01-03'
SCALE	6/1	ISSUE
		B
FILE NO.	F:\DWG\SSMB\1252Q1\50\3GT50G-B	

TITLE		<p style="text-align: center;">Amphenol</p> <p>Danbury, CT, USA - Tainan, Taiwan - Shenzhen, China</p>
SSMB R/A P.C. MOUNT JACK		
DRAWING NO.	SSMB1252Q1-3GT50G-50	
ITEM NO.	151252AAA02GAS5F	

A

B

C

D

E

F

A

B

C

D

E

F