

REVISIONS		
ISS	ZONE	DESCRIPTION\PER REQUEST\DATE

業務部

7/16-28UNEF-2B

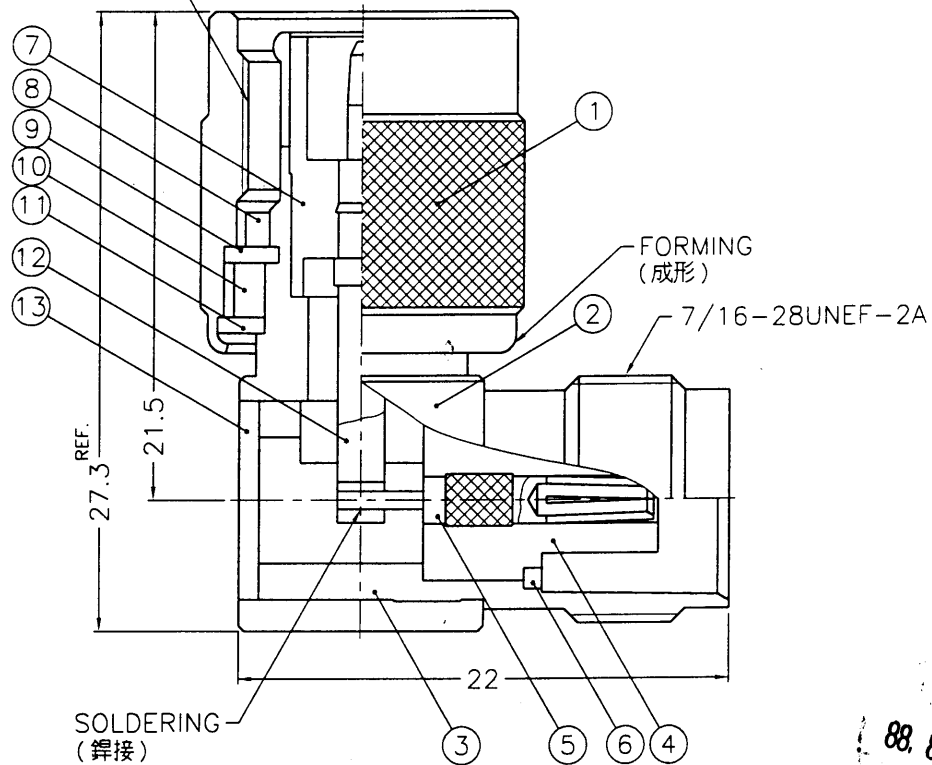

NOTES: FINISH (PLATING THICKNESS IN MICRO-INCHES)

1. BRASS PER QQ-B-626
2. BRASS PER QQ-B-613
3. NICKEL PL. 100 MIN. THICK OVER COPPER STRIKE
4. PHOSPHOR BRONZE PER QQ-B-750
5. GOLD PL. 3 MIN. THICK OVER NICKEL PL. 100 MIN. THICK OVER COPPER STRIKE
6. TEFLON MIL-P-19468

13	COVER	NOTE 2	NOTE 3	1	CV-895X07-T
12	CONTACT PIN	NOTE 1	NOTE 5	1	B5091-6-50
11	WASHER	NOTE 2	NOTE 3	1	WS-128/9X08
10	RING	DELIN	NATURAL	1	T50000-6-A
9	RETAINER RING	NOTE 1	NOTE 3	1	B50000-5
8	GASKET	RUBBER	RED	1	GS-105/8X15
7	INSULATOR	NOTE 6	NATURAL	1	ATC B-3000-3T-50
6	LOCK RING	NOTE 2	NOTE 3	1	B7700-4
5	CONTACT PIN	NOTE 4	NOTE 5	1	B5990-5
4	INSULATOR	NOTE 6	NATURAL	1	B5990-4T-50-A
3	BODY	NOTE 1	NOTE 3	1	T5990-3
2	HOUSING	NOTE 1	NOTE 3	1	B7996-2
1	SHELL	NOTE 1	NOTE 3	1	T50000-1-B
NO.	DESCRIPTION	MATERIAL	FINISH	Q'TY	DRAWING NO.

DIMENSIONS ARE IN MILLIMETERS
UNLESS OTHERWISE SPECIFIED TOLERANCES

0.5-6	= ±0.2
6-30	= ±0.4
30-120	= ±0.6
120-315	= ±1
315-1000	= ±1.6
1000-2000	= ±2.4

PART NO.	
APPROVED	DATE 08-17-99'
CHECKED	DATE 08-17-99'
DRAWN	DATE 08-17-99'



KAI JACK INDUSTRIAL CO., LTD.
TAINAN TAIWAN R.O.C.

TITLE
TNC MALE TO FEMALE R/A ADAPTOR

DRAWING NO.
KJ-T5072A1-NT3G-50

FILE NO. F:\DWG\T\5072A1\50\NT3G

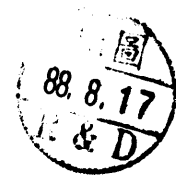

88072034