

REVISIONS		
ISS	ZONE	DESCRIPTION\PER REQUEST\DATE
A2	D-3	DESIGN WAS CHANGED\N/A\09-09-02'

SALES

REMARK: MUST WITHSTAND 3 psi FOR 1 MINUTE WITHOUT LEAKAGE.
(須能承受壓力 3psi/1min)

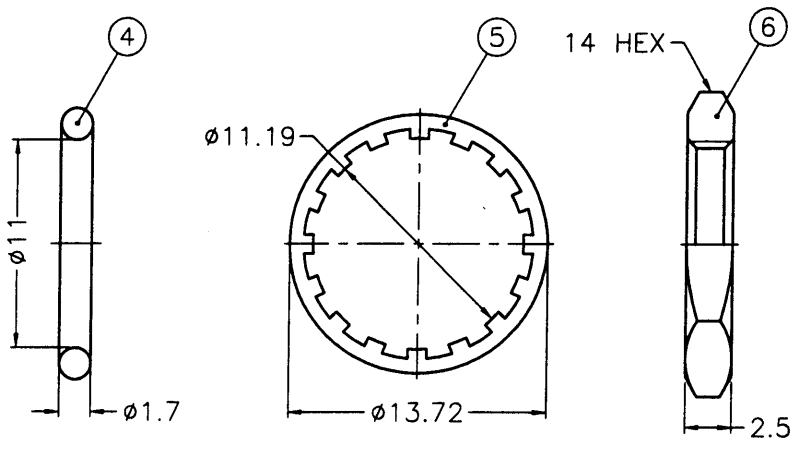
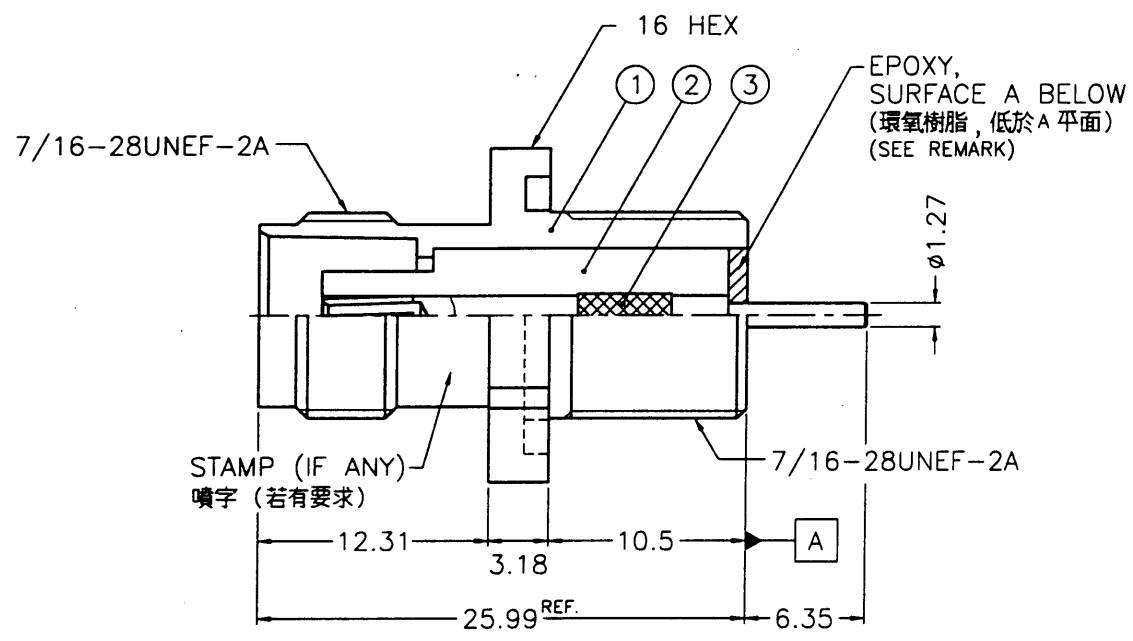
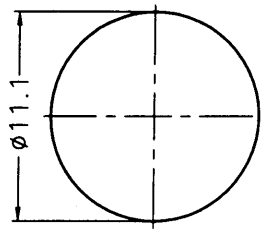

- NOTES: FINISH (PLATING THICKNESS IN MICRO-INCHES)
- BRASS PER QQ-B-626
 - PHOSPHOR BRONZE PER QQ-B-750
 - NICKEL PL. 100 MIN. THICK OVER COPPER STRIKE
 - GOLD PL. 30 MIN. THICK OVER NICKEL PL. 100 MIN. THICK OVER COPPER STRIKE
 - BERYLLIUM COPPER PER QQ-C-530
 - TEFLON MIL-P-19468

1. MAX. PANEL THICKNESS=7mm

DIMENSIONS ARE IN MILLIMETERS					PART NO.		Amphenol - Kai Jack					
6	HEX NUT	NOTE 1	NOTE 3	1	HN14-7/16-28X25	APPROVED	DATE	TAINAN TAIWAN				
5	LOCK WASHER	NOTE 2	NOTE 3	1	LW-1372/1119X05	<i>Asok C</i>	09-09-02'	TITLE				
4	GASKET	SILICONE	RED	1	GS-144/11XD17	CHECKED	DATE	TNC BULKHEAD RECEPT. JACK				
3	CONTACT PIN	NOTE 5	NOTE 4	1	CP01AKY01A	<i>Karl J.</i>	09-09-02'	DRAWING NO.				
2	INSULATOR	NOTE 6	NATURAL	1	NS01AKG01A	<i>Angelaw</i>	09-09-02'	KJ-T6351A3-001-NT30G-50				
1	BODY	NOTE 1	NOTE 3	1	BD02ABV01A			ITEM NO.				
NO.	DESCRIPTION	MATERIAL	FINISH	Q'TY	DRAWING NO.	SCALE	2.5/1	ISSUE	A2	FILE NO.	F:\DWG\T\6351A3\001\50\NT30G-A2	026351AAF02NC5F