

1	2	3	4	5	6	7	8
ISS	ZONE	REVISIONS					
		DESCRIPTION\PER REQUEST\DATE					

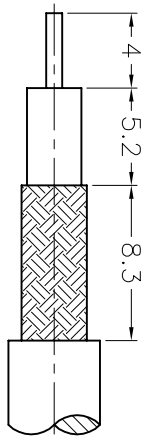

RECOMMENDED
CABLE STRIPPING DIM'S

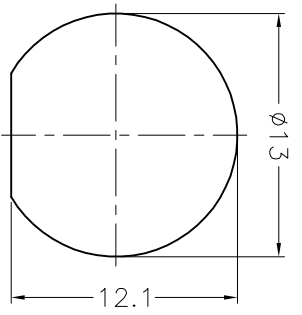

RECOMMENDED
MOUNTING HOLE

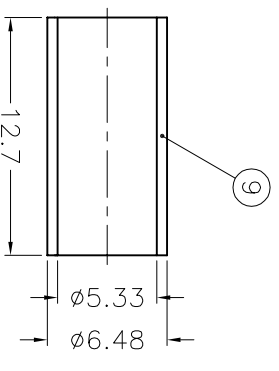
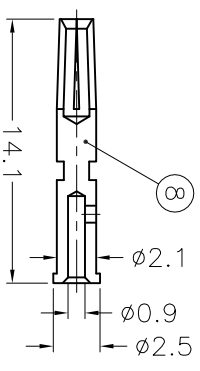
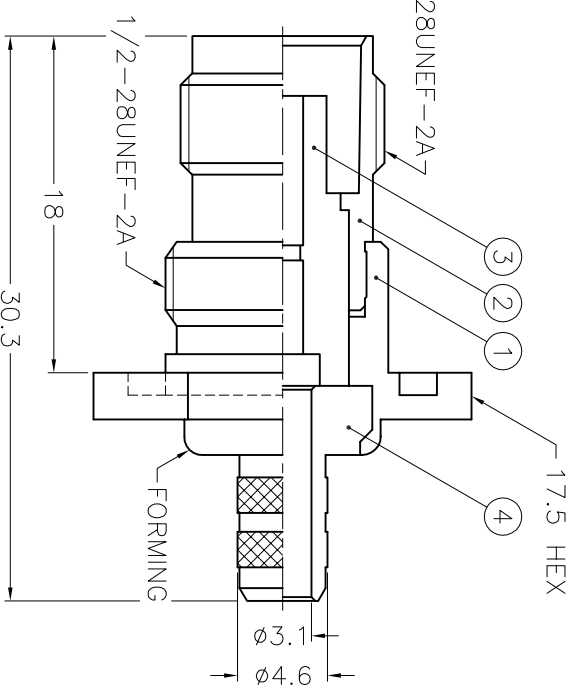
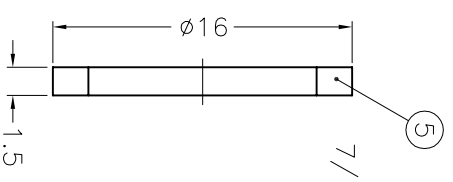
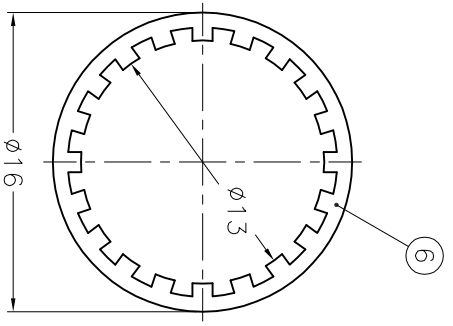
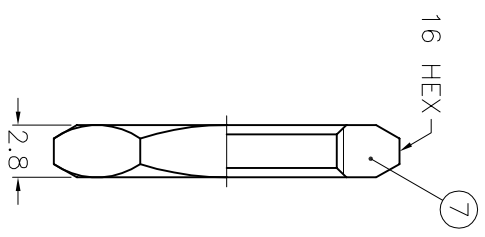

NOTES: FINISH (PLATING THICKNESS IN MICRO-INCHES)
 1. BRASS PER 00-B-626
 2. BRASS PER 00-B-613
 3. NICKEL PL. 100 MIN. THICK OVER COPPER STRIKE
 4. PHOSPHOR BRONZE PER 00-B-750
 5. GOLD PL. 3 MIN. THICK OVER NICKEL PL. 100 MIN. THICK OVER COPPER STRIKE
 6. TEFLON MIL-P-19468

9	FERRULE	COPPER	NOTE 3	1	FR-648/533X	127C
8	CONTACT PIN	NOTE 4	NOTE 5	1	B74000-8-25/09	
7	HEX NUT	NOTE 1	NOTE 3	1	HN16-1/2-28X28	
6	LOCK WASHER	NOTE 2	NOTE 3	1	LW-16/13X05	
5	GASKET	RUBBER	RED	1	GS-16/122X15	
4	BARREL	NOTE 1	NOTE 3	1	B74000-4-46/31	
3	INSULATOR	NOTE 6	NATURAL	1	B74000-3T-50	
2	BODY	NOTE 1	NOTE 3	1	T74000-2	
1	HOUSING	NOTE 1	NOTE 3	1	B74000-1	

DIMENSIONS ARE IN MILLIMETERS
 UNLESS OTHERWISE SPECIFIED
 TOLERANCES
 0.5-6 = ± 0.2
 6-30 = ± 0.4
 30-120 = ± 0.6
 120-315 = ± 1
 315-1000 = ± 1.6
 1000-2000 = ± 2.4

PART NO.	DATE
APPROVED	03-25-99'
CHECKED	03-25-99'
DRAWN	03-25-99'

KAI JACK INDUSTRIAL CO., LTD.
 TAINAN TAIWAN R.O.C.

TITLE
 TNC BULKHEAD CRIMP JACK

DRAWING NO.
 KJ-T6421A1-NT3G-58U-50

FILE NO. F:\DWG\T\6421A1\58U-50\NT3G

1 2 3 4 5 6 7 8