

REVISIONS		
ISS	ZONE	DESCRIPTION\PER REQUEST\DATE

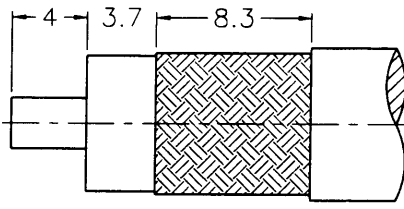

RECOMMENDED
CABLE STRIPPING DIM'S
(建議剝線尺寸)

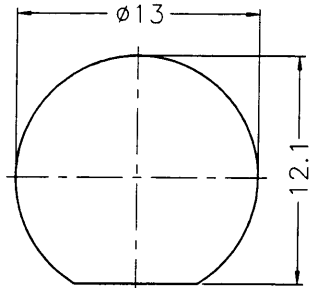

RECOMMENDED
MOUNTING HOLE
(建議架設孔)

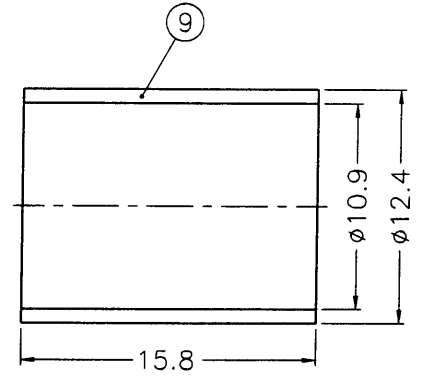
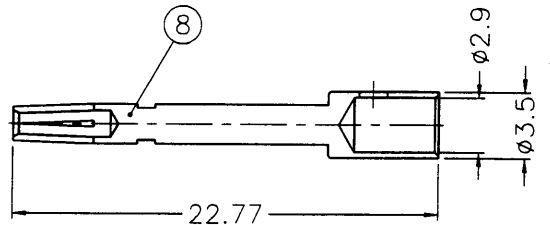
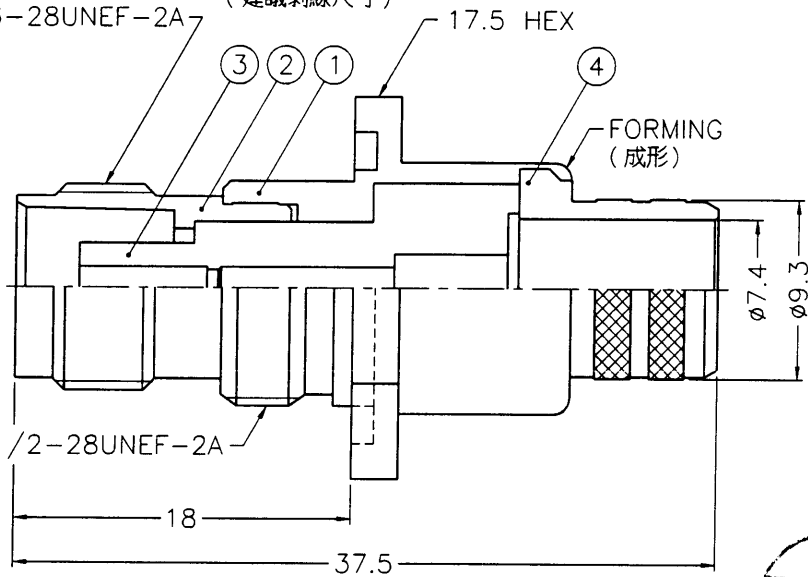
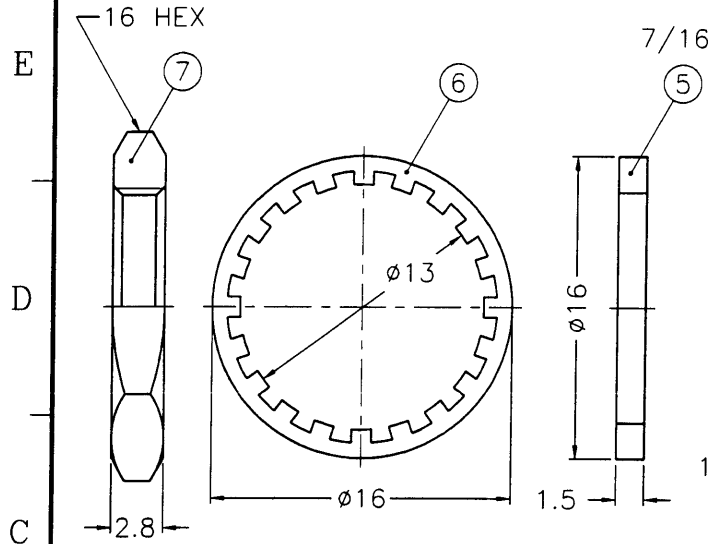

- NOTES: FINISH (PLATING THICKNESS IN MICRO-INCHES)
- BRASS PER QQ-B-626
 - BRASS PER QQ-B-613
 - NICKEL PL. 100 MIN. THICK OVER COPPER STRIKE
 - PHOSPHOR BRONZE PER QQ-B-750
 - GOLD PL. 3 MIN. THICK OVER NICKEL PL. 100 MIN. THICK OVER COPPER STRIKE
 - TEFLON MIL-P-19468
 - JIS H3250, C 2700

- CRIMPED FERRULE
HEX CRIMP SIZE .429"
- CRIMPED CONTACT PIN
HEX CRIMP SIZE .118"



9	FERRULE	NOTE 7	NOTE 3	1	FR-124/109X158
8	CONTACT PIN	NOTE 4	NOTE 5	1	B6421A6-8-35/29
7	HEX NUT	NOTE 1	NOTE 3	1	HN16-1/2-28X28
6	LOCK WASHER	NOTE 2	NOTE 3	1	LW-16/13X05
5	GASKET	RUBBER	RED	1	GS-16/122X15
4	BARREL	NOTE 1	NOTE 3	1	N5000-3-93/74
3	INSULATOR	NOTE 6	NATURAL	1	B6421A6-3T-50-9913
2	BODY	NOTE 1	NOTE 3	1	T74000-2
1	HOUSING	NOTE 1	NOTE 3	1	B6421A6-1
NO.	DESCRIPTION	MATERIAL	FINISH	Q'TY	DRAWING NO.

DIMENSIONS ARE IN MILLIMETERS	
UNLESS OTHERWISE SPECIFIED TOLERANCES	
0.5-6	= ±0.2
6-30	= ±0.4
30-120	= ±0.6
120-315	= ±1
315-1000	= ±1.6
1000-2000	= ±2.4

PART NO.	
APPROVED	DATE
CHECKED	DATE
DRAWN	DATE

Amphenol - Kai Jack	
TAINAN TAIWAN	
TITLE	TNC BULKHEAD CRIMP JACK (FOR BELDEN 8214, 9913, 9914)
DRAWING NO.	KJ-T6421A6-NT3G-9913-50
FILE NO.	F:\DWG\T\6421A6\9913-50\NT3G