

REVISIONS		
ISS	ZONE	DESCRIPTION\PER REQUEST\DATE

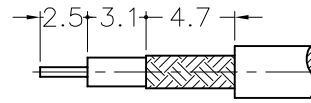

RECOMMENDED CABLE STRIPPING DIM'S

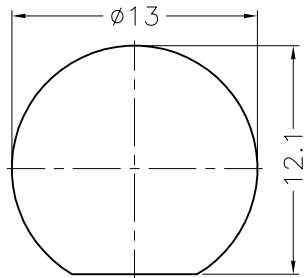

RECOMMENDED MOUNTING HOLE

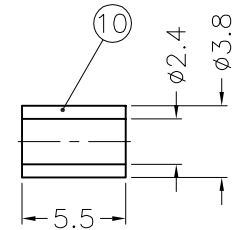
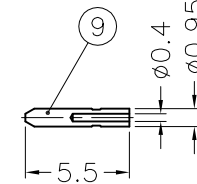
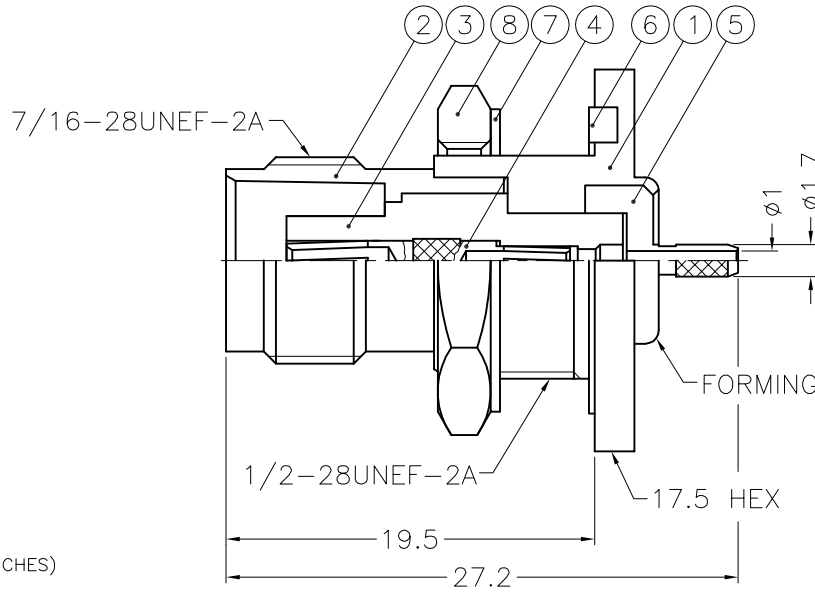

NOTES: FINISH (PLATING THICKNESS IN MICRO-INCHES)

- 1. BRASS PER QQ-B-626
- 2. BRASS PER QQ-B-613
- 3. NICKEL PL. 100 MIN. THICK OVER COPPER STRIKE
- 4. PHOSPHOR BRONZE PER QQ-B-750
- 5. GOLD PL. 3 MIN. THICK OVER NICKEL PL. 100 MIN. THICK OVER COPPER STRIKE

NO.	DESCRIPTION	MATERIAL	FINISH	Q'TY	DRAWING NO.
10	FERRULE	COPPER	NOTE 3	1	FR-38/24X55C
9	CONTACT PIN	NOTE 1	NOTE 5	1	B50003-9-0.4
8	HEX NUT	NOTE 1	NOTE 3	1	HN16-1/2-28X28
7	LOCK WASHER	NOTE 2	NOTE 3	1	LW-16/13X05
6	GASKET	RUBBER	RED	1	GS-16/122X15
5	BARREL	NOTE 1	NOTE 3	1	B6421G1-5-17/1
4	CONTACT PIN	NOTE 4	NOTE 5	1	B6421G1-4-1.05
3	INSULATOR	DELRIN	NATURAL	1	B6421G1-3-50-B
2	BODY	NOTE 1	NOTE 3	1	T74000-2
1	HOUSING	NOTE 1	NOTE 3	1	B6421G1-1-B

DIMENSIONS ARE IN MILLIMETERS

UNLESS OTHERWISE SPECIFIED TOLERANCES

- 0.5-6 = ±0.2
- 6-30 = ±0.4
- 30-120 = ±0.6
- 120-315 = ±1
- 315-1000 = ±1.6
- 1000-2000 = ±2.4

SCALE 2.5/1 ISSUE A

PART NO.	
APPROVED	DATE 04-03-99'
CHECKED	DATE 04-03-99'
DRAWN	DATE 04-03-99'



KAI JACK INDUSTRIAL CO., LTD.
TAINAN TAIWAN R.O.C.

TITLE	
TNC BULKHEAD CRIMP JACK (FOR RG-178B/U, 196A/U)	
DRAWING NO. KJ-T6421G1-002-ND3G-196AU-50	
FILE NO. F:\DWG\T\6421G1\002\196AU-50\ND3G	