

1 2 3 4 5 6 7 8

REVISIONS		
ISS	ZONE	DESCRIPTION\PER REQUEST\DATE
A2	D-6	NO.1 WAS CHANGED\N/A\04-16-02'

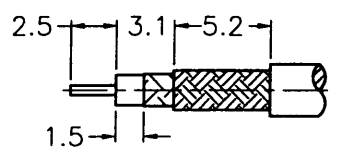

RECOMMENDED  
CABLE STRIPPING DIM'S  
(建議剝線尺寸)

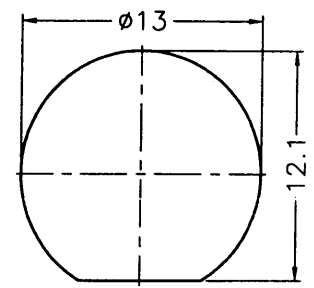

RECOMMENDED  
MOUNTING HOLE  
(建議架設孔)

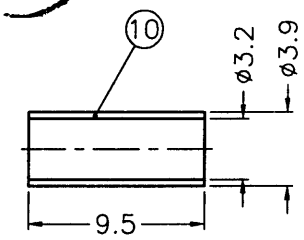
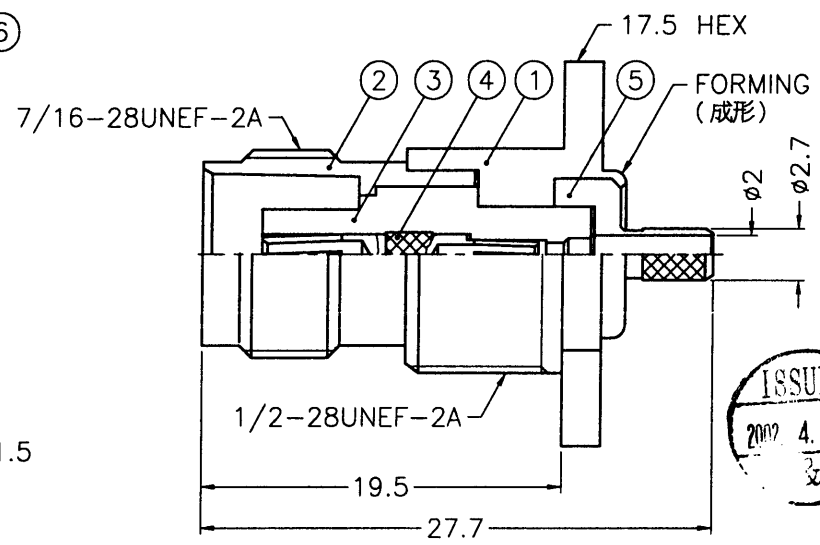
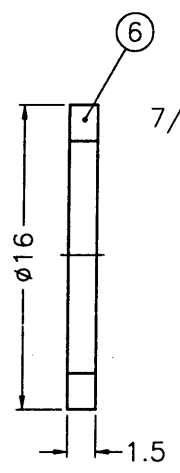
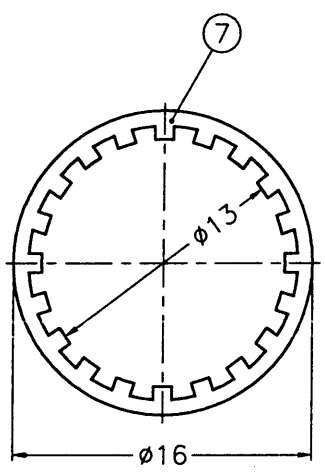
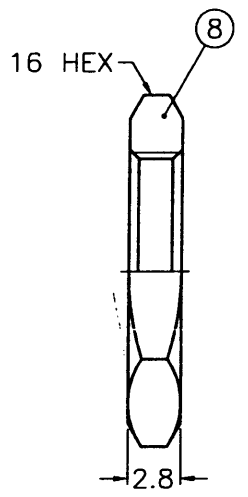

1. CRIMPED FERRULE  
HEX CRIMP SIZE .128"
2. CRIMPED CONTACT PIN  
SQ. CRIMP SIZE 0.7mm
3. MAX. PANEL THICKNESS=5mm

NOTES: FINISH (PLATING THICKNESS IN MICRO-INCHES)  
 1. BRASS PER QQ-B-626  
 2. BRASS PER QQ-B-613  
 3. NICKEL PL. 100 MIN. THICK OVER COPPER STRIKE  
 4. PHOSPHOR BRONZE PER QQ-B-750  
 5. GOLD PL. 3 MIN. THICK OVER NICKEL PL. 100 MIN. THICK OVER COPPER STRIKE  
 6. JIS H3250, C 2600

NO.	DESCRIPTION	MATERIAL	FINISH	Q'TY	DRAWING NO.
10	FERRULE			1	FR-39/32X95
9	CONTACT PIN			1	B50003-9-0.6
8	HEX NUT			1	HN16-1/2-28X28
7	LOCK WASHER			1	LW-16/13X05
6	GASKET	RUBBER	RED	1	GS-16/122X15
5	BARREL			1	BROOALA02A
4	CONTACT PIN			1	B6421G1-4-1.05
3	INSULATOR	DELTRIN	NATURAL	1	B6421G1-3-50-B
2	BODY			1	T74000-2
1	HOUSING			1	HS00AJR01A

DIMENSIONS ARE IN MILLIMETERS				PART NO.	
UNLESS OTHERWISE SPECIFIED TOLERANCES				APPROVED	DATE
0.5-6	= ±0.2			<i>A. R. C.</i>	04-16-02'
6-30	= ±0.4			CHECKED	DATE
30-120	= ±0.6			<i>Karl J.</i>	04-16-02'
120-315	= ±1			DRAWN	DATE
315-1000	= ±1.6			<i>Angela W.</i>	04-16-02'
1000-2000	= ±2.4			FILE NO.	F:\DWG\T\6421G1\007\50\ND3G

Amphenol - Kai Jack	
TAINAN TAIWAN	
TITLE	TNC BULKHEAD CRIMP JACK
DRAWING NO.	KJ-T6421G1-007-ND3G-50
ITEM NO.	026421ABAA2ND5F

A

A

1 2 3 4 5 6 7 RD-DR/141878