

1 2 3 4 5 6 7 8

業務部

REVISIONS		
ISS	ZONE	DESCRIPTION\APPROVED\DATE

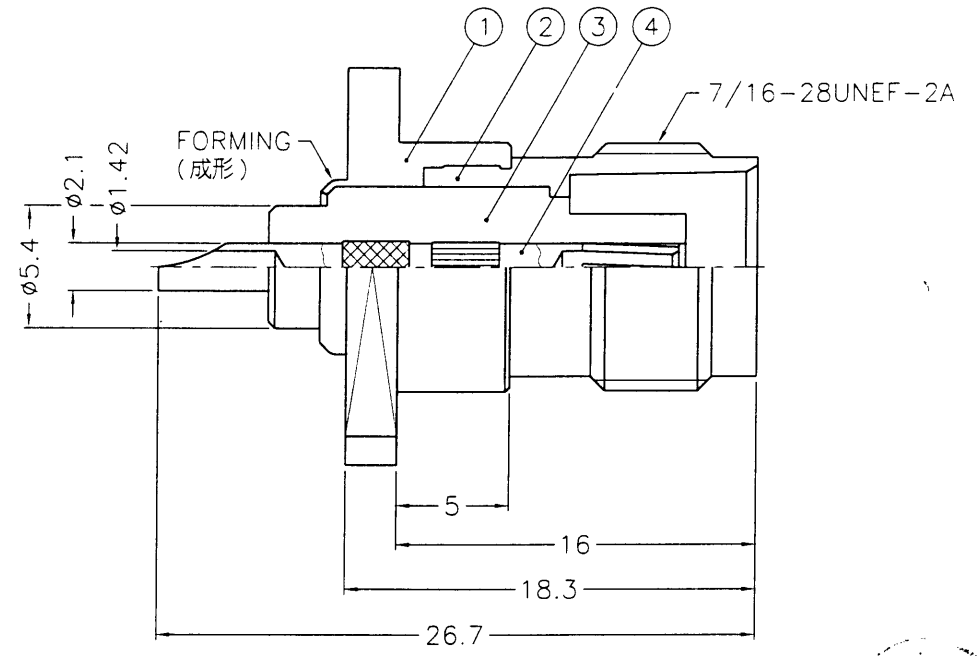
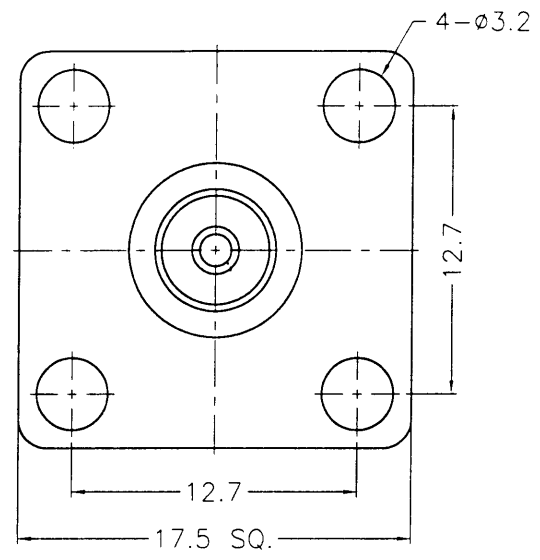

- NOTES: FINISH (PLATING THICKNESS IN MICRO-INCHES)
1. BRASS PER QQ-B-626
  2. NICKEL PL. 100 MIN. THICK OVER COPPER STRIKE
  3. PHOSPHOR BRONZE PER QQ-B-750
  4. GOLD PL. 3 MIN. THICK OVER NICKEL PL. 100 MIN. THICK OVER COPPER STRIKE
  5. TEFLON MIL-P-19468



DIMENSIONS ARE IN MILLIMETERS					PART NO.			
UNLESS OTHERWISE SPECIFIED TOLERANCES					APPROVED	DATE		TITLE
0.5-6 = ±0.2						08-17-99'	TNC PANEL JACK	
6-30 = ±0.4							CHECKED	DATE
30-120 = ±0.6						08-17-99'	DRAWING NO.	
120-315 = ±1							DRAWN	DATE
315-1000 = ±1.6						08-17-99'	KJ-T6551A1-NT3G-50	
1000-2000 = ±2.4							SCALE	3/1
NO.	DESCRIPTION	MATERIAL	FINISH	Q'TY	DRAWING NO.	FILE NO.	F:\DWG\T\6551A1\50\NT3G	

4	CONTACT PIN	NOTE 3	NOTE 4	1	B7310-3-50
3	INSULATOR	NOTE 5	NATURAL	1	B75300-3T-50-B
2	BODY	NOTE 1	NOTE 2	1	T74000-2
1	HOUSING	NOTE 1	NOTE 2	1	B75300-1

1 2 3 4 5 6 7 8

8TR1101