

1 2 3 4 5 6 7 8

REVISIONS		
ISS	ZONE	DESCRIPTION\APPROVED\DATE

業務部

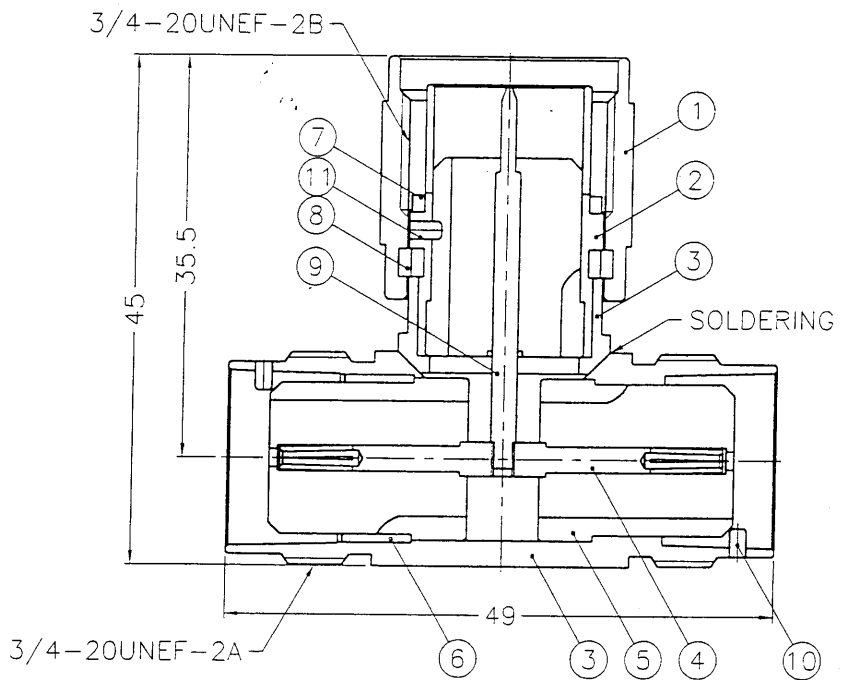

NOTES: FINISH (PLATING THICKNESS IN MICRO-INCHES)
 1. BRASS PER QQ-B-626
 2. NICKEL PL. 100 MIN. THICK OVER COPPER STRIKE
 3. PHOSPHOR BRONZE PER QQ-B-750
 4. GOLD PL. 3 MIN. THICK OVER NICKEL PL. 100 MIN. THICK OVER COPPER STRIKE

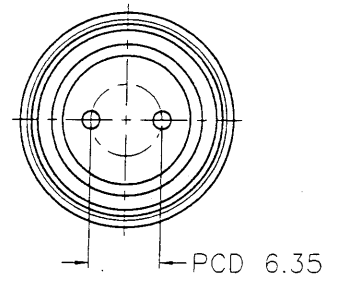

出圖
87.12.09
R&D

11	PIN	NOTE 1	NOTE 2	1	TW5620-12
10	PIN	NOTE 1	NOTE 2	2	TW7630-8
9	CONTACT PIN	NOTE 1	NOTE 4	2	TW7996-10
8	RETAINER RING	SUS 304	NATURAL	1	N5000-7-C
7	GASKET	SILICONE	RED	1	GS-17/145X15
6	RING	NOTE 1	NOTE 2	1	TW7690-4
5	INSULATOR	PBT	WHITE	3	TWX6351B1-2
4	CONTACT PIN	NOTE 3	NOTE 4	2	TW7996-5
3	HOUSING WITH BODY	NOTE 1	NOTE 2	1	TWX9073A1-3S
2	CONTACT BODY	NOTE 1	NOTE 2	1	TW7996-2
1	SHELL	NOTE 1	NOTE 2	1	TW5620-1
NO.	DESCRIPTION	MATERIAL	FINISH	Q'TY	DRAWING NO.

DIMENSIONS ARE IN MILLIMETERS
 UNLESS OTHERWISE SPECIFIED TOLERANCES
 0.5-6 = ±0.2
 6-30 = ±0.4
 30-120 = ±0.6
 120-315 = ±1
 315-1000 = ±1.6
 1000-2000 = ±2.4

PART NO.	
APPROVED	DATE
CHECKED	DATE
DRAWN	DATE

<p>KAI JACK INDUSTRIAL CO., LTD. TAINAN TAIWAN R.O.C.</p>	
TITLE	
TWINAXIAL FEMALE-MALE-FEMALE ADAPTOR	
DRAWING NO.	
KJ-TWX9073A1-NPB3G-95	
FILE NO.	
F:\DWG\TWX\9073A1\95\NPB3G	

F
E
D
C
B
A

1 2 3 4 5 6 7 8 ADT-R0403