

REVISIONS		
ISS	ZONE	DESCRIPTION\PER REQUEST\DATE

業務部

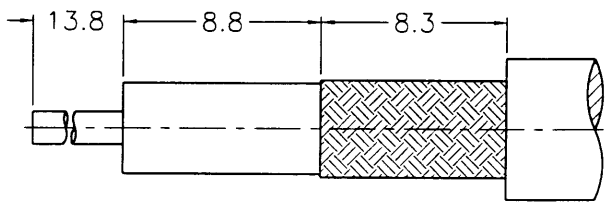

RECOMMENDED
CABLE STRIPPING DIM'S
(建議剝線尺寸)

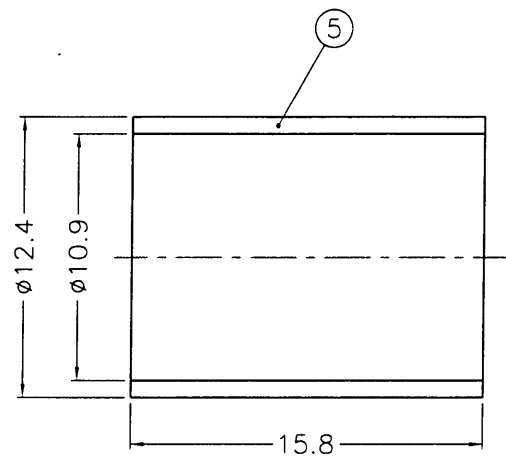
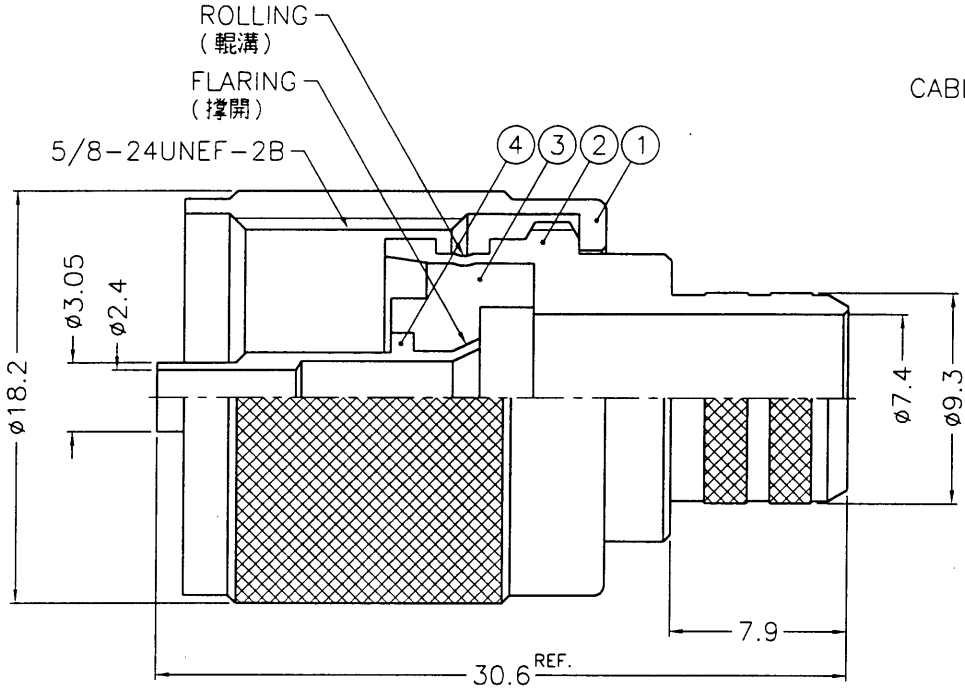

88.5.27
K & D

NOTES: FINISH (PLATING THICKNESS IN MICRO-INCHES)
 1. BRASS PER QQ-B-626
 2. NICKEL PL. 100 MIN. THICK OVER COPPER STRIKE
 3. SILVER PL. 200 MIN. THICK OVER COPPER STRIKE
 4. PHENOLIC, YELLOW PER PANTONE 110C
 5. JIS H 3250, C 2700

DIMENSIONS ARE IN MILLIMETERS				PART NO.	
UNLESS OTHERWISE SPECIFIED TOLERANCES				APPROVED <i>Mark C</i> DATE 05-24-99'	
0.5-6 = ±0.2				CHECKED <i>Mark C</i> DATE 05-24-99'	
6-30 = ±0.4				DRAWN <i>Ala</i> DATE 05-24-99'	
30-120 = ±0.6					
120-315 = ±1					
315-1000 = ±1.6					
1000-2000 = ±2.4					

<p>KAI JACK INDUSTRIAL CO., LTD. TAINAN TAIWAN R.O.C.</p>	TITLE	UHF CRIMP PLUG
	DRAWING NO.	KJ-U1121A1-NPHS-8U-50
	FILE NO.	F:\DWG\U\1121A1\8U-50\NPHS

NO.	DESCRIPTION	MATERIAL	FINISH	Q'TY	DRAWING NO.
5	FERRULE	NOTE 5	NOTE 2	1	FR-124/109X158
4	CONTACT PIN	NOTE 1	NOTE 3	1	U5000-4-305/24
3	INSULATOR	NOTE 4	NOTE 4	1	U5290-3PHE-50
2	BODY	NOTE 1	NOTE 2	1	U5000-2-93/74
1	SHELL	NOTE 1	NOTE 2	1	U5000-1

A