

| REVISIONS |      |                                                         |  |
|-----------|------|---------------------------------------------------------|--|
| ISS       | ZONE | DESCRIPTION\PER REQUEST\DATE                            |  |
| B         | B-2  | HN00AAF14A WAS B5205-12-95/54\ RD-DM92012402W\01-24-03' |  |

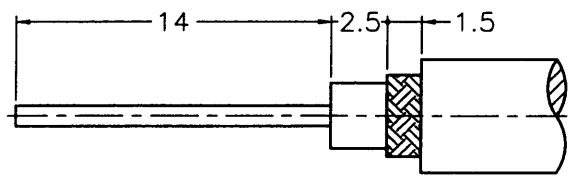

**SALES**

RECOMMENDED  
CABLE STRIPPING DIM'S  
(建議剝線尺寸)

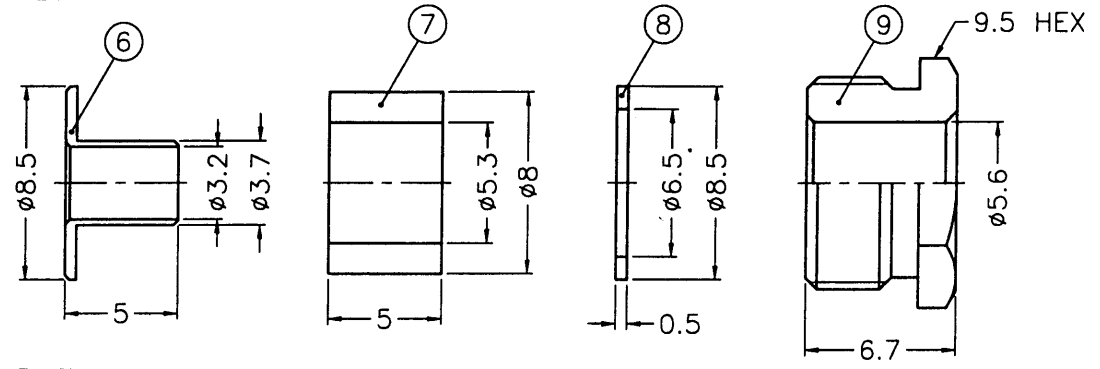
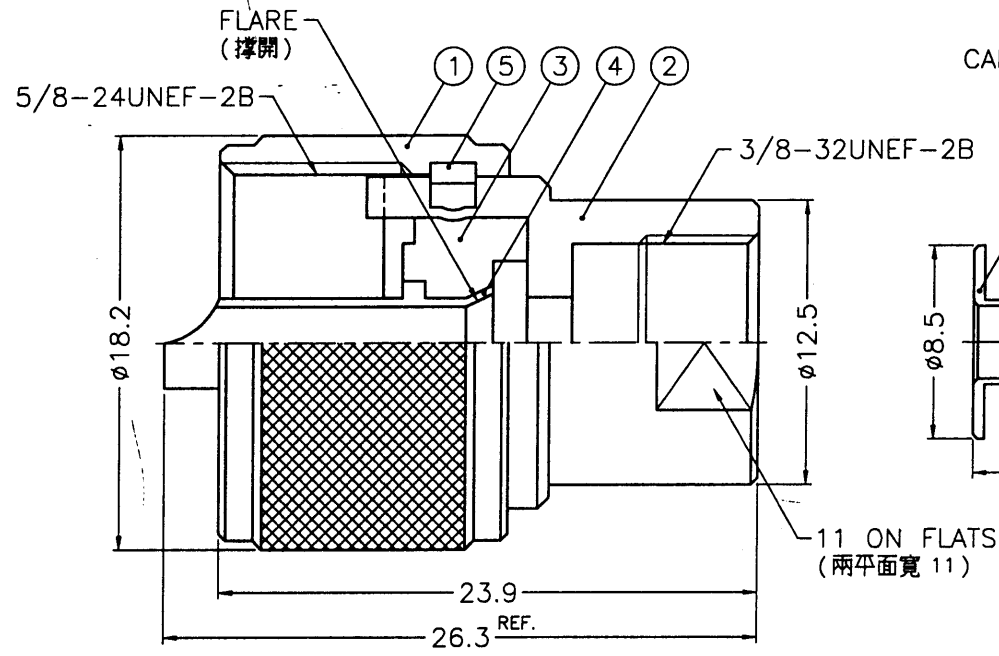

- NOTES: FINISH (PLATING THICKNESS IN MICRO-INCHES)
- BRASS PER QQ-B-626
  - BRASS PER QQ-B-613
  - SILVER PL. 80 MIN. THICK OVER COPPER STRIKE
  - SILVER PL. 200 MIN. THICK OVER COPPER STRIKE
  - TEFLON MIL-P-1946B
  - NICKEL PL. 100 MIN. THICK OVER COPPER STRIKE

ISSUED  
2003. 2. 20  
R&D

| NO. | DESCRIPTION   | MATERIAL | FINISH  | Q'TY | DRAWING NO.      |
|-----|---------------|----------|---------|------|------------------|
| 9   | HEX NUT       | NOTE 1   | NOTE 3  | 1    | HN00AAF14A       |
| 8   | WASHER        | NOTE 2   | NOTE 3  | 1    | WS-85/65X05      |
| 7   | GASKET        | SILICONE | RED     | 1    | GS-8/53X5        |
| 6   | TOP HAT       | NOTE 1   | NOTE 3  | 1    | B1141E1-11-37/32 |
| 5   | RETAINER RING | NOTE 1   | NOTE 6  | 1    | PT-4000-001-7    |
| 4   | CONTACT PIN   | NOTE 1   | NOTE 4  | 1    | U5290-4          |
| 3   | INSULATOR     | NOTE 5   | NATURAL | 1    | U1141A1-3        |
| 2   | BODY          | NOTE 1   | NOTE 3  | 1    | U1141A1-2        |
| 1   | SHELL         | NOTE 1   | NOTE 3  | 1    | PT-4000-001-1    |

| DIMENSIONS ARE IN MILLIMETERS         |        |       |   | PART NO.       |                               |
|---------------------------------------|--------|-------|---|----------------|-------------------------------|
| UNLESS OTHERWISE SPECIFIED TOLERANCES |        |       |   | APPROVED       | DATE                          |
| 0.5-6                                 | = ±0.2 |       |   | <i>AOK. C</i>  | 02-19-03'                     |
| 6-30                                  | = ±0.4 |       |   |                |                               |
| 30-120                                | = ±0.6 |       |   | CHECKED        | DATE                          |
| 120-315                               | = ±1   |       |   | <i>Stacy W</i> | 02-19-03'                     |
| 315-1000                              | = ±1.6 |       |   | DRAWN          | DATE                          |
| 1000-2000                             | = ±2.4 |       |   | <i>Stacy W</i> | 02-19-03'                     |
| SCALE                                 | 3/1    | ISSUE | B | FILE NO.       | F:\DWG\U\1141A1\58CU\50\STS-B |

**Amphenol**  
Danbury, CT, USA - Tainan, Taiwan - Shenzhen, China

TITLE UHF SOLDER CLAMP PLUG  
(FOR RG-58C/U, 58/U, 142A/U, RG-223/U)

DRAWING NO. U1141A1-STS-58CU-50

ITEM NO. 061141AAA57SM5F

A

A