

REVISIONS		
ISS	ZONE	DESCRIPTION\PER REQUEST\DATE
B	A-3	NO.3 WAS CHANGED\RD-DM06072801C\08-14-06'
C	A-3	NO.4 WAS CHANGED\RD-DM06121501J\12-19-06'
D	A-3	NO.4 WAS CHANGED\RD-DM07060601K\06-16-07'

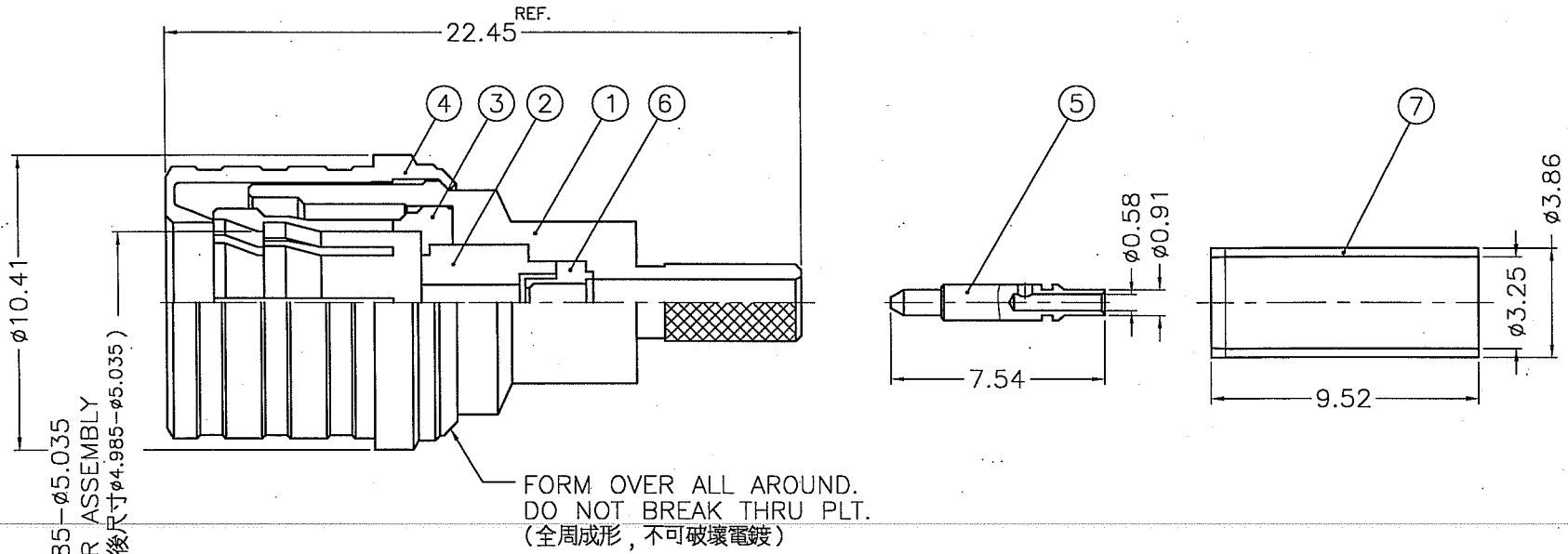

FORM OVER ALL AROUND.
DO NOT BREAK THRU PLT.
(全周成形, 不可破壞電鍍)

NOTES: FINISH (PLATING THICKNESS IN MICRO-INCHES):

1. BRASS PER QQ-B-626
2. PHOSPHOR BRONZE PER QQ-B-750
3. GOLD PL. 30 MIN. THICK OVER ALBALOY PLATING (COPPER-TIN-ZINC) PL. 80 MIN. THICK
4. ALBALOY PLATING (COPPER-TIN-ZINC) PL. 80 MIN. THICK
5. TEFLON MIL-P-19468

REMARK: 1. NO.4 MUST BE FREE TURNING AND MUST BE CAPABLE OF WITHSTANDING A PULL-OFF FORCE OF 30 LBS. MIN. AFTER FORMING
(NO.4 成形後可自由轉動且至少需承受 30 LBS.的拉力)

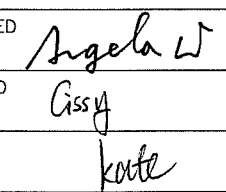
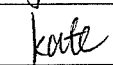
DIMENSIONS ARE IN MILLIMETERS						PART NO.		<h2 style="text-align: center;">Amphenol</h2> <p style="text-align: center;">Danbury,CT,USA-Tainan,Taiwan-Shenzhen,China</p>		
UNLESS OTHERWISE SPECIFIED TOLERANCES						APPROVED	DATE			TITLE
7	FERRULE	COPPER	NOTE 4	1	31-1357-3		06-16-07'			QMA 50 OHM PLUG FOR RG-316 TYPE CABLE
6	INSULATOR	NOTE 5	NATURAL	1	930-10064		06-16-07'			
5	CONTACT PIN	NOTE 1	NOTE 3	1	930-10062		06-16-07'			
4	SLEEVE	NOTE 1	NOTE 4	1	930-10004		06-16-07'			
3	OUTER CONTACT	NOTE 2	NOTE 4	1	930-10003#B	DRAWN	DATE	DRAWING NO.		
2	INSULATOR	NOTE 5	NATURAL	1	930-10063		06-16-07'	930-129P-51S		
1	BODY	NOTE 1	NOTE 4	1	930-10061		06-16-07'	ITEM NO.	930-129P-51S	
NO.	DESCRIPTION	MATERIAL	FINISH	Q'TY	DRAWING NO.	SCALE	4/1	ISSUE	D	FILE NO. F:\DWG\CNPD\930\129P\51S-DSZ