

NOTES: FINISH(PLATING THICKNESS IN MICRO-INCHES)

- PLATING PER AMPHENOL SPEC. 349-50560.(FOR USA)  
PLATING PER KAI JACK SPEC. EP-SS-9700.(FOR CHINA)  
SUMMARY:

31-1357-7	ALBALOY PLATING (COPPER-TIN-ZINC) PL. 80 MIN.THICK
BD70ACQ01	ALBALOY PLATING (COPPER-TIN-ZINC) PL. 80 MIN.THICK
930-10142	GOLD PL. 30 MIN. THICK OVER COPPER PL. 100 MIN. THICK
930-10004	ALBALOY PLATING (COPPER-TIN-ZINC) PL. 80 MIN.THICK
TC70AAA01	ALBALOY PLATING (COPPER-TIN-ZINC) PL. 80 MIN.THICK

- ITEM 8,9 IS PACKAGED LOOSE. ITEM 8,9 為散裝件
- SLEEVE (ITEM 2 ) MUST BE FREE TURNING AND MUST BE CAPABLE OF WITHSTANDING A PULL-OFF FORCE OF 30 LBS. MIN. AFTER FORMING.

外殼需能自由轉動且可承受 30 LBS.拉力

THIRD ANGLE PROJ.

REVISIONS

REV	DESCRIPTION	DATE	ECO	APPR
A	RELEASE TO MFG	17-May-12		JS



SCALE 1:000

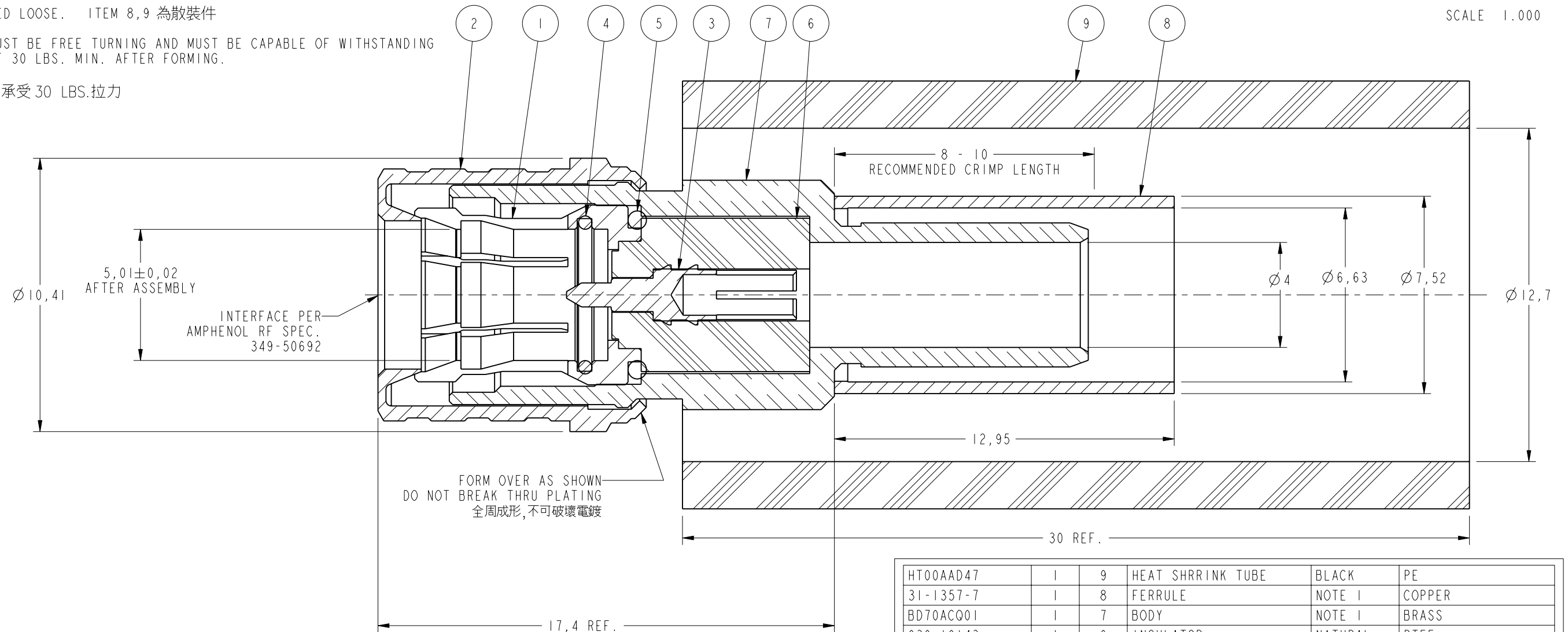

- MATING WITH QMA JACK MUST WITHSTAND 8 PSI INTERNAL AIR PRESSURE FOR A DURATION OF HALF MINUTE SUBMERGED WITH NO VISIBLE LEAKAGE

接上 QMA 母頭能夠承受 8 PSI 氣壓，半分鐘不會產生氣泡。

HT00AAD47	1	9	HEAT SHRRINK TUBE	BLACK	PE
31-1357-7	1	8	FERRULE	NOTE 1	COPPER
BD70ACQ01	1	7	BODY	NOTE 1	BRASS
930-10143	1	6	INSULATOR	NATURAL	PTFE
GS00ACK01	1	5	GASKET	BLACK	NBR70
930-10173	1	4	O-RING	NATURAL	EPDM 70
930-10142	1	3	CONTACT	NOTE 1	PHOSPHOR BRONZE
930-10004	1	2	SLEEVE	NOTE 1	BRASS
TC70AAA01	1	1	OUTER CONTACT	NOTE 1	PHOSPHOR BRONZE
PART NUMBER	QTY.	ITEM	DESCRIPTION	FINISH	MATERIAL

UNLESS OTHERWISE SPECIFIED, DIMENSIONS ARE IN METRIC AND TOLERANCES ARE:  
0.5 - 6mm ±0.1mm    6 - 30mm ±0.2mm    30 - 120mm ±0.3mm    ANGLES ±1°

NOTICE - These drawings, specifications, or other data (1) are, and remain the property of Amphenol corp. (2) must be returned upon request; and (3) are confidential and not to be disclosed to any person other than those to whom they are given by Amphenol Corp. the furnishing of these drawings, specifications, or other data by Amphenol Corp., or to any other person to anyone for any purpose is not to be regarded by implicatioin or otherwise in any manner licensing, granting rights to permitting such holder or any other sperson to manufacture, use or sell any product, process or design, patented or otherwsie, that may in any way be related to or disclosed by said drawings, specifications, or other data.

MATERIAL  
REFERENCE EAR# 4618  
CONFIGURATION LEVEL:  
FINISH

DRAWN J. SHAO  
ENGINEER F. WANG  
APPROVED S. HSIEH  
CAD FILE I:\QMA\QMA1111A1-AT30GA-LMR240-50  
DATE 17-May-12  
DATE 17-May-12  
DATE 17-May-12

TITLE  
QMA (M) STRIAGHT  
CRIMP PLUG, IP67  
TO S67163, LMR-240  
SCALE: 6.0:1.0 SHEET 1 OF 2  
DWG SIZE B CODE ID 74868 REV A

**Amphenol RF**  
Danbury CT USA, Tainan, Taiwan, Shenzhen, China  
www.amphenolrf.com  
DRAWING NO. QMA1111A1-AT30GA-LMR240-50  
ITEM NO. 701111AADA1AG5F  
PART NO.