

NOTES:

1. MATERIAL AND FINISH (PLATING THICKNESS IN MICRO-INCHES):
 BODY - BRASS, GOLD PLATING
 CONTACT - BERYLLIUM COPPER, GOLD PLATING
 INSULATOR - PTFE, NATURAL
2. ELECTRICAL:
 A. IMPEDANCE: 50 OHM
 B. FREQUENCY RANGE: 0-6 GHz
 C. DIELECTRIC WITHSTANDING VOLTAGE: 750 VRMS. MIN.
3. MECHANICAL:
 A. DURABILITY: 100 CYCLES MIN.
 B. TEMPERATURE RANGE: -40°C TO + 85°C
 C. WEIGHT: 6.25±0.3g
4. PACKAGING: TAPE AND REEL
 RECOMMENDED QUANTITY: 250 PCS PER REEL

THIRD ANGLE PROJ.

REVISIONS

REV	DESCRIPTION	DATE	ECO	APPR
A	RELEASE TO MFG.	24-Jun-10	---	JH
B	ADD PACKAGING /RD-DM10112501J4	29-Nov-10	---	S.H

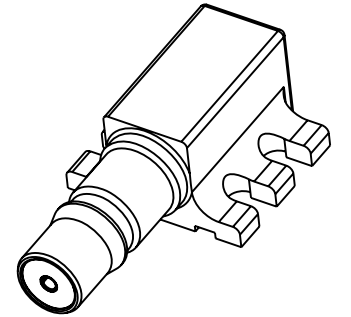

SCALE 2.000

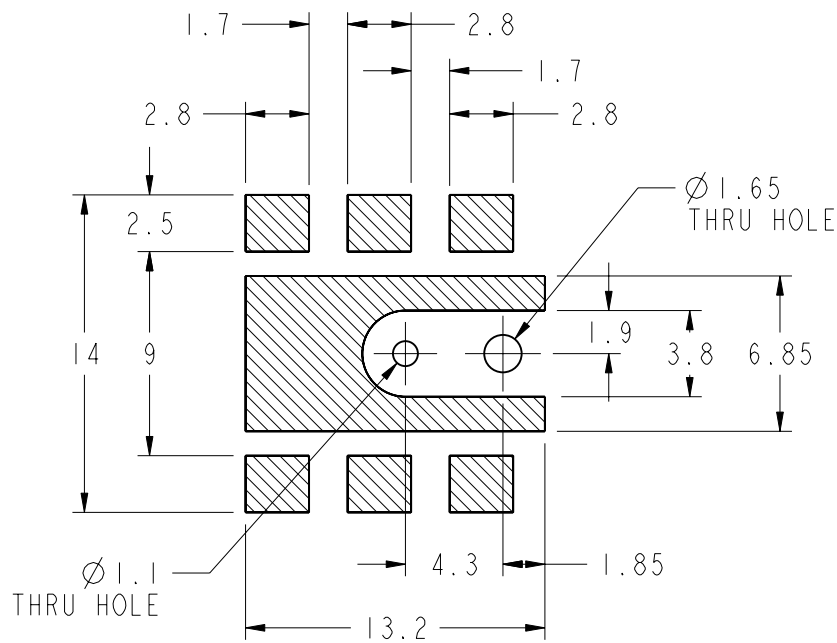
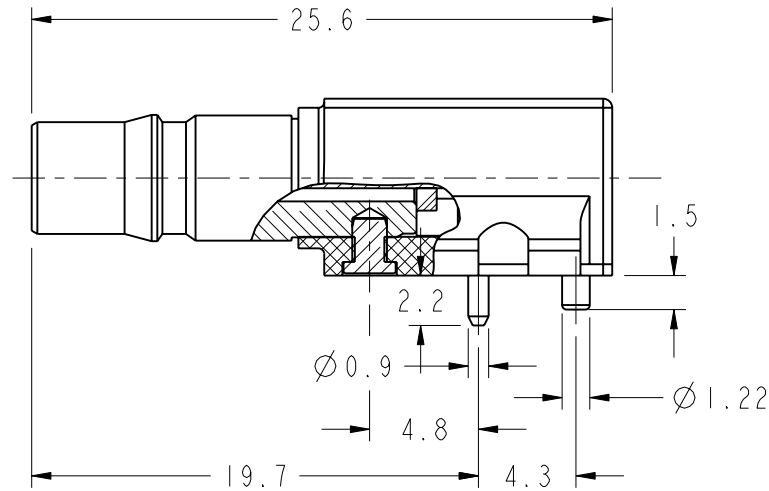
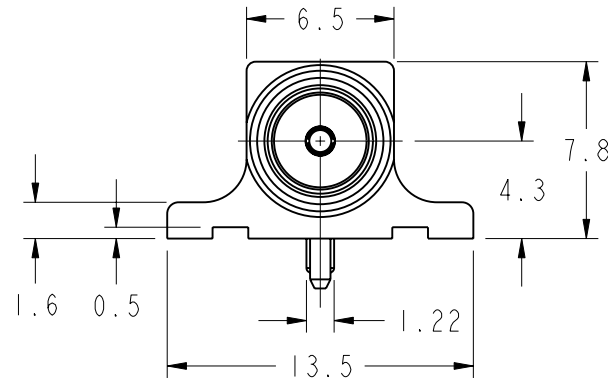

RECOMMENDED PCB LAYOUT
(FOR REF ONLY)

SCALE 3.000

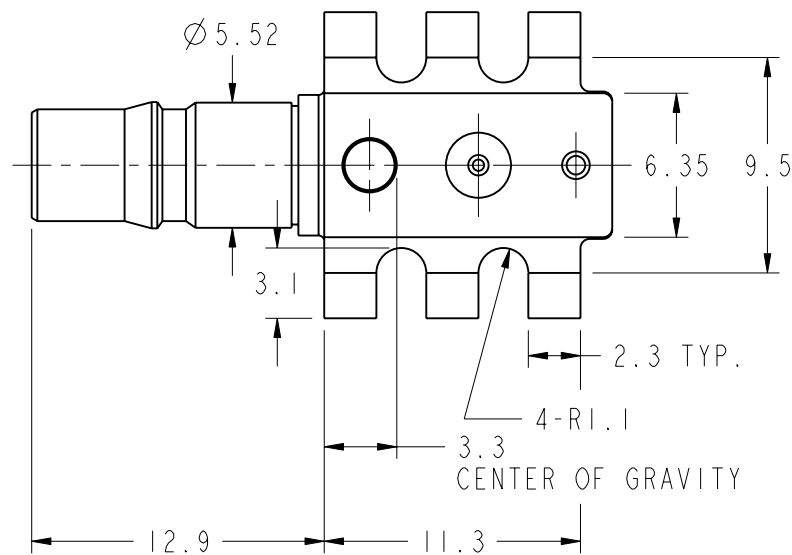

CUSTOMER OUTLINE DRAWING

ALL OTHER SHEETS ARE FOR INTERNAL USE ONLY

UNLESS OTHERWISE SPECIFIED, DIMENSIONS ARE IN METRIC AND TOLERANCES ARE:
 0.5 - 6mm ±0.1mm
 6 - 30mm ±0.2mm
 30 - 120mm ±0.3mm
 ANGLES ±1°

NOTICE - These drawings, specifications, or other data (1) are, and remain the property of Amphenol corp. (2) must be returned upon request; and (3) are confidential and not to be disclosed to any person other than those to whom they are given by Amphenol Corp. the finishing of these drawings, specifications, or other data by Amphenol Corp., or to any other person for any purpose is not to be regarded by implication or otherwise in any manner licensing, granting rights to permitting such holder or any other person to manufacture, use or sell any product, process or design, patented or otherwise, that may in any way be related to or disclosed by said drawings, specifications, or other data.

MATERIAL	DRAWN JASON	DATE 29-Nov-10	TITLE QMA RECEPTACLE SURFACE MOUNT		Amphenol RF Danbury CT USA, Tainan, Taiwan, Shenzhen, China www.amphenolrf.com	
REFERENCE	ENGINEER DANIEL	DATE 24-Jun-10				
FINISH	APPROVED SCOTT.H	DATE 29-Nov-10	SCALE: 3.0:1.0	SHEET 2 OF 2	DRAWING NO. QMA6252D1-001-20GT30G-50	
	CAD FILE I:\QMA\QMA6252D1-001-20GT30G-50		DWG SIZE B	CODE ID 74868	REV B	ITEM NO. 706252AAMAIRP5F
						PART NO.